

MAKING BUILDINGS MORE INTELLIGENT



A Managed Internet of Things (IoT) solution for Building Management

A high-performance building automation solution for monitoring and controlling the different systems across your facility. The solution seamlessly integrates with different systems, equipment and field devices that control your access, occupancy, heating, ventilation and air conditioning (HVAC), energy consumption, lighting, hydraulics, water, electrical equipment, ERP and much more.

DID YOU KNOW?

3-5%

Of revenue spent on energy by commercial/industrial organization with annual revenue >USD 10Bn

Many enterprises spend as much as \$500M / year on energy. Most senior executives remain unaware of how much they spend on energy even today

3-5%

40%

50%

40%

Of the world's energy is consumed by buildings – far more than the transportation sector*.

Architects and builders are focusing on making new buildings as green as possible and operators of existing buildings are looking for ways to conserve energy.

50%

Of the companies that experiences a data/security breach was due to Bring Your Own device (BYOD).

Rather than respond with ever tightening restrictions/policies, IT managers should consider recognizing these risks and embracing BYOD with the right solutions.

Smart buildings – the promise of IoT

Buildings are complex ecosystems that need engineering and maintenance staff to continuously monitor and manage systems controlling occupancy, lighting, temperatures, air quality, security and communications.

As part of sustainability objectives that are namely, conserving energy, delivering excellent client service and well-being of workforce, enterprises across the world seek assistance of real-estate companies in delivering “Connected” commercial real-estate solutions. Real-estate companies already made significant progress in developing industry-leading strategies, tools and technologies that help clients improve energy efficiency and control associated costs with the help of energy management solutions in the market. They are now focusing on the individual occupant experience and cost savings via efficient space utilization. Powered by data and actionable analytics they believe they can deliver best-in-class workplace strategies.

With improved tracking of assets (equipment, machinery, tools and etc.) using sensors and connectivity, businesses can benefit from real-time insights and visibility into their assets and supply

chains. For instance, they could more easily locate assets and run preventive maintenance on critical pieces of infrastructure and machinery to improve throughput and utilization. Also, for office-based organizations, personnel costs can be up to 90% of operational costs. With this focus on top-line revenues, even small increases in worker productivity can result in considerable savings. There is a growing body of research that demonstrates how green design features can positively enhance the health, well-being and productivity of employees through improvements to the physical environment such as light, air quality, indoor temperature, noise and space. This issue is a growing concern for many clients of real-estate companies. A survey conducted on this issue by a leading commercial real-estate services company (conducted in 2010) found that an increasing number of executives recognized the value of enhancing workplace strategies that promote employee health, well-being and productivity.

A managed IoT Solutions promises more opportunities for intelligent automation in the built environment. Extending today's building automation through intelligence, security, modularity, and intuitive interfaces that allow autonomous operations, smart buildings have the potential to transform our living and work experiences.

Business Drivers for Smart Building Solutions

Financial

- Reduce Total Cost of Ownership
- Improved return on assets
- Competitive differentiation

Stakeholders & Workforce

- Enable mobility & flexibility
- Mitigate risk
- Provide safety and comfort
- Improve workforce productivity

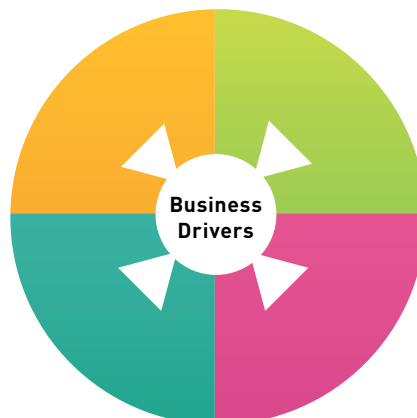

Business Process

- Optimize operations
- Streamline Services
- Enable business intelligence
- Reduces operational expenses

Community

- Environmental sustainability
- Social responsibility
- Brand recognition

THE CHALLENGES IN REALIZING THE PROMISE

Highly fragmented ecosystem

Failing to see the value in strategic alignment different systems in a facility typically operate in functional silos mainly due to

- Huge resistance from the construction teams to change from traditional specialty trades to consolidated systems
- Design teams and suppliers not agreeing upon the approach, coordination, and integration amongst disciplines
- Specs organization not usually oriented to Smart Buildings
- Suppliers not willing to cooperate with each other

Interoperability

The number of connected devices would be 18.9 Bn by 2016 – without small devices (*). Prescriptively defining each device's language is bound to fail for IoT at scale. Intelligent buildings need to transcend integration to achieve interaction in which the previously independent systems work collectively to optimize overall performance and constantly create an environment that is most conducive to the smart building needs and goals.

Security and Privacy

The wireless connectivity that makes connected homes/buildings smart via IoT can also make them vulnerable to unauthorized intrusion—cyber and physical.

MANAGED IOT SOLUTIONS FOR SMART BUILDINGS

Real estate companies need a strong partner not only to help them overcome these challenges but also to improve operational efficiency by delivering an integrated solution.

- Transform the way space/asset utilization was monitored and controlled
- Improve occupant ambience
- Improve Real Time Situational Awareness and Analysis
- Enhance security and safety via location sensors
- Enforce stronger authentication methods

Sensing this need, HARMAN Connected Services built a high-performance building automation solution for monitoring and controlling the different systems across your facility. The solution seamlessly integrates with different systems, equipment and field devices that control your access, occupancy, heating, ventilation and air conditioning (HVAC), energy consumption, lighting, hydraulics, water, electrical equipment, ERP systems and much more.

Key Solution Differentiators

- Managed Services for Smart Building with actionable analytics
- Unmatched Data Visualization and real time notifications
- Faster roll out – couple of weeks
- Integrates with legacy systems seamlessly

MANAGED IOT SOLUTIONS – ADDRESSING THE CHALLENGES

Customer Service and Efficiency

Referring to figure 1.

- Mobile/GPS mapping for maintenance staff to prioritize/optimize their route with least disruption to tenants
- Streamline conference room scheduling process and ensure allocations are done based on the number of occupants and other requirements (accessibility, catering, audio/video etc)
- Improve functional/productive space by monitoring and optimizing congested or common gathering areas

Fig. 1 – Workspace occupancy

Administrator is provided with real time occupancy data. Also providing information on unutilized spaces.

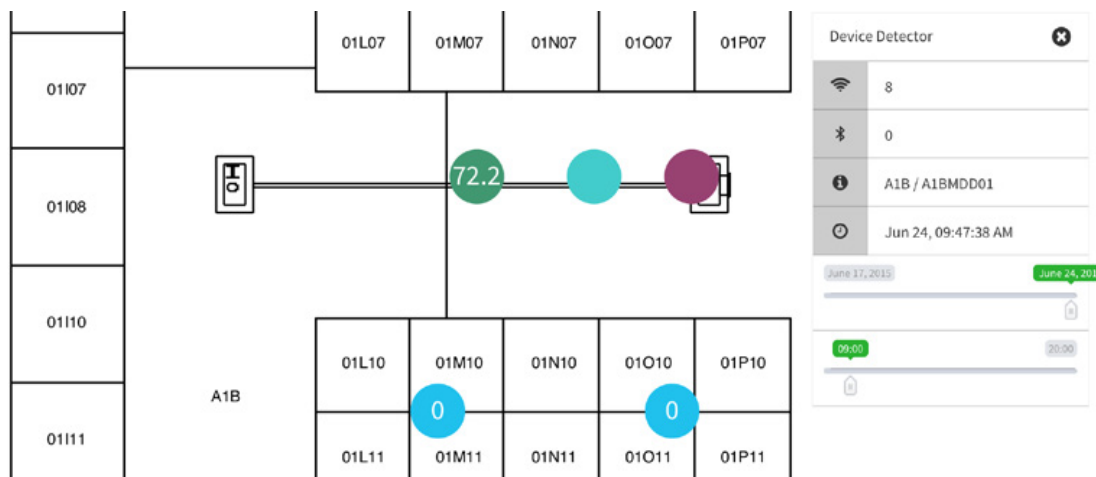
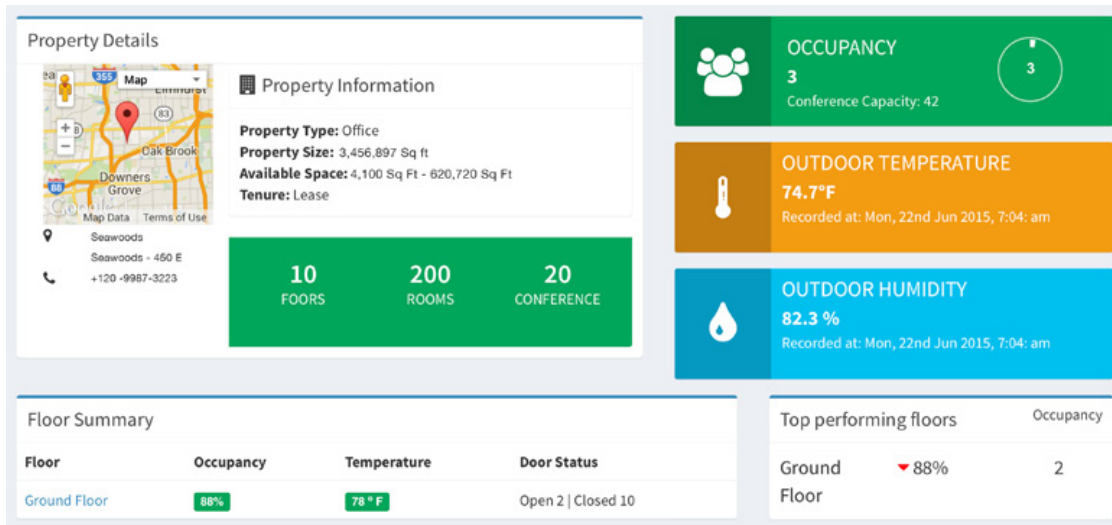

Fig. 2 – Utilization dashboards

Administrator is provided with an overview of the assets occupancy and utilization, indoor & outdoor temperatures.



Unmatched Security Management

Advanced resource management functionality such as integrated access control, time, attendance and intrusion detection. Refer to figure 2. Productivity improvement comes with one-screen data acquisition and supervisory control for different devices, applications and systems providing:

- Secure access to building with 2-factor authentication
- Access permissions based on predefined rules/parameters.
- Integrates with legacy systems
- Standard and custom reporting–
- Retrieve Video clips based on the events, alarms and etc
- Supports RFID, Card holders and biometric authentication

Improved return on assets

Identifying the booking versus actual asset utilization, capacity versus utilization of the asset and the climatic conditions of the facility helps operators improve the asset utilization thus saving cost and improved occupant experience. Refer to figure 3.

- Accurate leasing/cost projection – Predictive analytics used to calculate property taxes, real estate, inflation, and other attributes
- Gain competitive edge—“Smart Property Automation and Insights” can be bundled as a proprietary product/service offering
- Gain insights on under utilization of properties/rooms (Inadequate temp control, air quality, solar radiation, noise etc)

Fig. 3 – Performance of asset

Holistic overview with occupancy status of the room, conference rooms performance, climatic conditions.

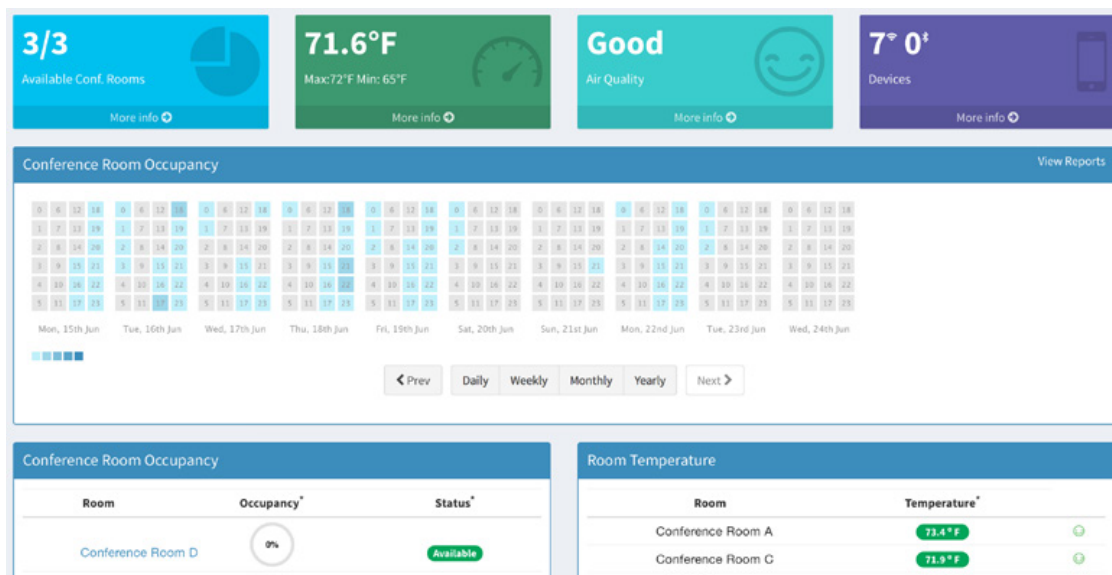
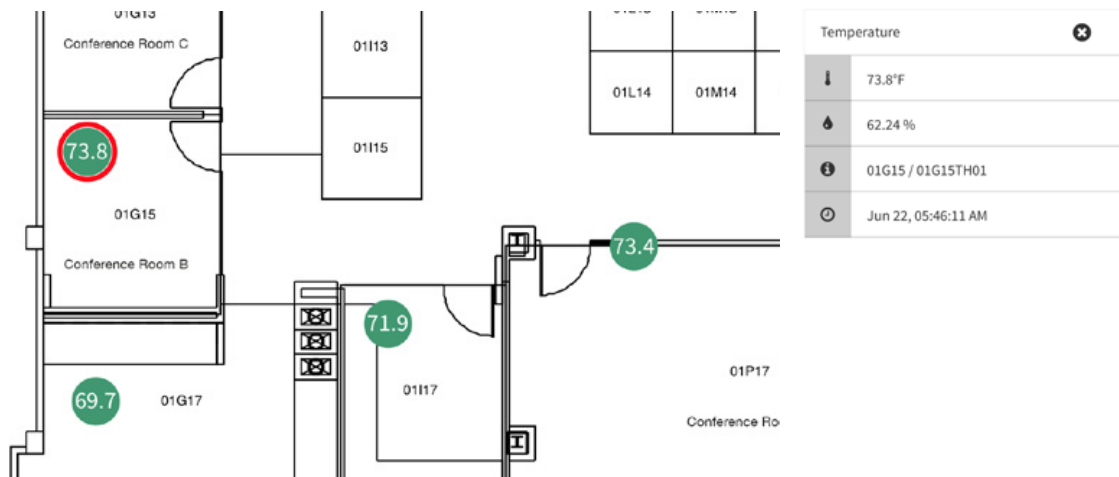

Fig. 4 – Energy efficiency

The administrator is provided with real time temperature data and threshold value indicators.



Energy efficient – Reduces costs

Real time data from HVAC systems not only reduces costs on scheduled maintenance but also improves the workforce productivity. Refer to figure 4.

- The HVAC system knows when to start heating/cooling based upon predictive analytics based on real-time ambient building/room temps, solar radiation, and first scheduled meetings.)
- Smart lighting can be implemented to turn on/off based upon motion detection or lack thereof.

Safe, Compliant and Productive operation

During critical situations, having access to early detection or early warning information can substantially reduce the impact to the loss of property or life. Trust Symphony Teleca as your partner in enabling you to provide a safer, complaint and productive operation mitigating any potential risk for better management in crisis. Refer to figure 5.

- Monitor & Manage building occupancy
- Mitigate safety risk and liability insurance by optimizing traffic flow and ease access to safety exists.
- In the event of an emergency, you may provide first responders with a count of occupants in a building or even their specific location if trapped inside.

Fig. 5 – Representative layout

Representative layout and real-time door status across the entire floor.

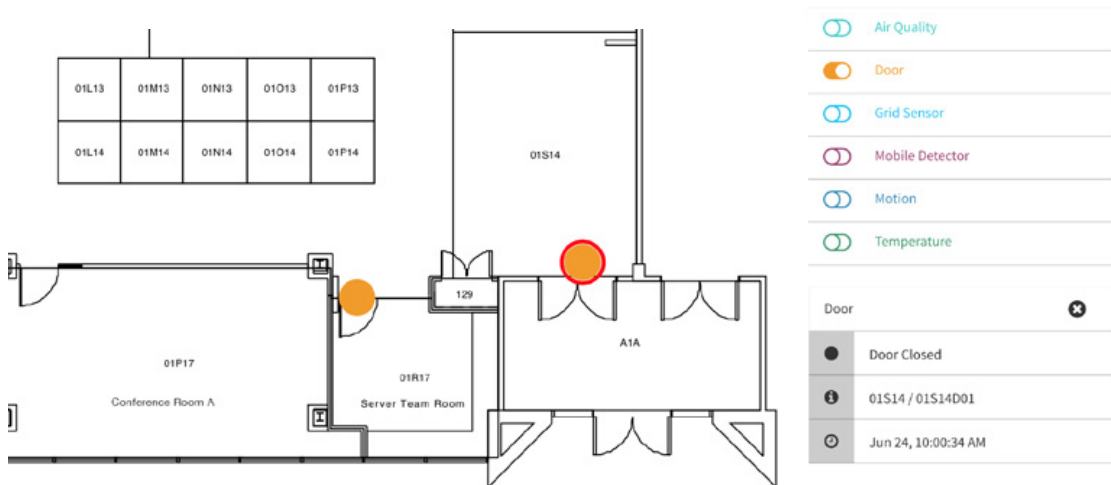

A TYPICAL WORK DAY—INTELLIGENT, COMFORTABLE, SECURE, SAFE AND ENERGY EFFICIENT

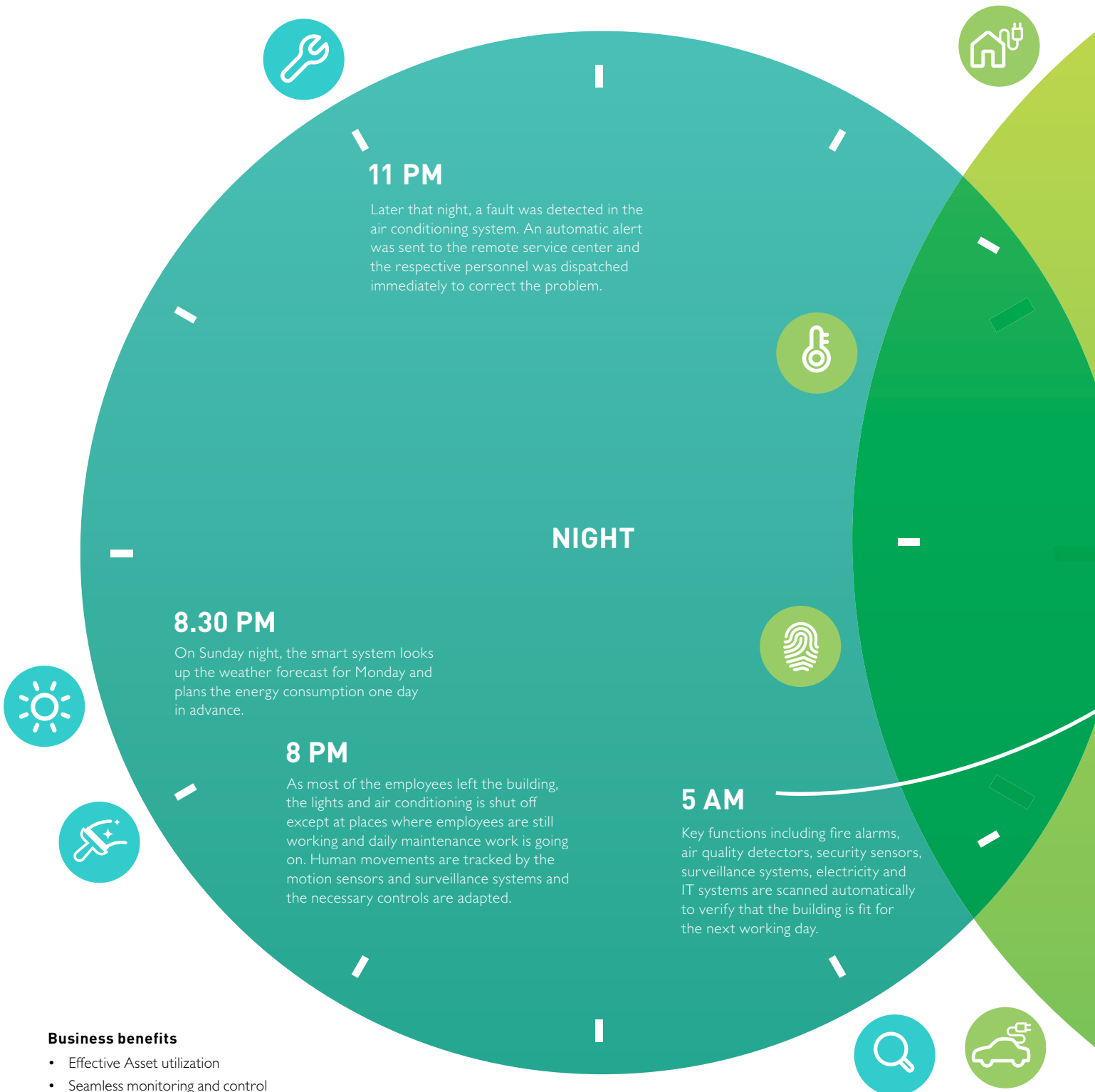

Business benefits

- Effective Asset utilization
- Seamless monitoring and control
- Quicker response time
- Accurate data
- Increased productivity
- Reduced risk of down-time and Exposure
- Secure Environment
- Significant cost savings

DAY

8.45 AM

The moment Ross tries to enter his building of work, the biometric authentication system recognizes Ross and sends him notification of the morning meeting at 9:30 am. Also the system detects that Ross is carrying a new tablet that he purchased recently. The system instructs Ross to register the device under BYOD policy and also instructs the IT team about the device.

8.30 AM

Ross arrives at work and realizes that his car is low on charge. He plugs it in at the building charging station using his key.

9.30 AM

More people attend Ross's meeting than expected. The sensors connected to the HVAC systems identify the occupancy levels and immediately adjust the ventilation and air conditioning levels so that the optimum environmental conditions are restored.

10.30 AM

Ross is asked to collate the energy consumption of the properties owned by their company. Thanks to the single point access, he was able to pull out the month's consumption pattern and also YoY comparisons.

6 PM

Ross rushes out of office in his fully charged electric car and forgets to switch off his system and the lights. Sensing his absence and the fact that he tapped out of the building using his keycard, the smart solution integrated with HRMS switches off everything down.

1 PM

As many employees are out for lunch the lights are dimmed and air conditioning power is lowered to conserve energy. This is done without any disruption to the employees.

2 PM

The system draws less power from the electric grid and relies on the power generated by the solar panels on the rooftop thus striking a balance between the renewable energy and supplied power



Features and Benefits

Real Time Situational Awareness & Analysis	<ul style="list-style-type: none">• Ethernet's bus topology makes wiring much simpler than the current copper pair and HDMI cabling.
Scheduling/Management System	<ul style="list-style-type: none">• E-AVB flexibility and 1722.I network management make configuration of complex networks simple and easy.
Global scheduling	<ul style="list-style-type: none">• The IEEE 802.1Qat Stream Reservation Protocol (SRP) provides mechanisms for reserving stream bandwidth that allows endpoint applications to configure the routes, eliminating the need for specific network engineering.
Support for 500+ sensors	<ul style="list-style-type: none">• Ethernet AVB protocols ensure end-to-end timely delivery time of all media streams.• Guarantees maximum of 2ms latency in case of Class A and a 50ms latency for class B streams.
IoT Gateway reference solution	<ul style="list-style-type: none">• The IEEE 802.1AS Precision Time Protocol (PTP) provides. A common time reference base to all nodes on the network. PTP can• measure and compensate for all queuing and time-of-flight transmission delays.
Cloud Ready	<ul style="list-style-type: none">• AVB networks utilize bandwidth only between source and destination node connections.• Topologies such as bus, stars, trees or rings are easily supported.
Domain expertise	<ul style="list-style-type: none">• Including error logging support for debugging, testing and analyzing.
High security and authentication	<ul style="list-style-type: none">• Safeguarding device operations.
High bandwidth	<ul style="list-style-type: none">• Ensuring secured data, QoS and future expansions.• Supports all Ethernet rates: 10Mbps, 100Mbps, 1 Gbps and 10 Gbps.
IEEE 802.1 Audio Video Bridging (AVB)	<ul style="list-style-type: none">• The AVB protocols are open standards, allowing multiple suppliers to deliver silicon solutions for consumer electronics usage.

Partner with an industry expert

HARMAN Connected Services, a leader in software design and development, helps global brands dramatically reduce time-to-market while improving quality and productivity. Our end-to-end software engineering, IoT and data analytics services enable the world's top automotive, mobile and communications and software-enabled businesses drive innovation-led growth. Via our over-the-air (OTA) software update, virtualization and device management solutions we keep billions of mobile, automotive and IoT devices of all sizes and complexity continuously and reliably relevant and secure. The mobile devices and intelligent systems that we power are connected, integrated and protected across all platforms and reach every corner of today's digital world. HARMAN Connected Services is a division of HARMAN (NYSE:HAR), the leading global infotainment, audio and software services company.

Visit our website at www.harman.com

